

MTE-S 20.20

Meter test station for twenty measurement positions

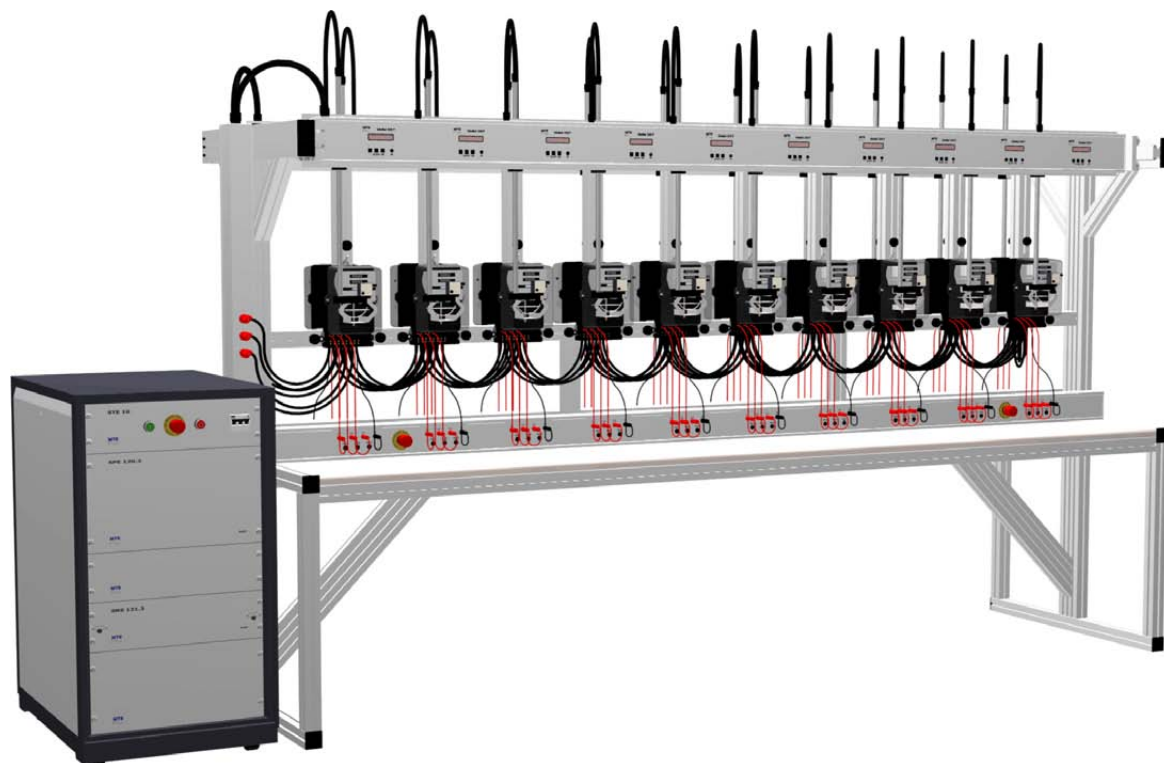

The MTE-S 20.20 Meter Test Station is designed to test up to twenty single or three phase electricity meters at the same time. It is fully electronic, using only solid-state electronic components and is operated via a personal computer.

The MTE-S 20.20 enables fully automatic meter calibration and verification procedures to be carried out. A complementary printer, available as optional equipment, will complete the installation allowing the user to printout comprehensive test reports. The installation, which has a precision of 0.05 %, can be used for testing both Ferraris and Electronic type meters.

Power Source

The power source creates a three-phase network, using a base of electronically generated sine waves. This network is completely independent of the supply voltage, and the use of a voltage stabiliser at the entry point is not necessary.

Integrated power amplifiers are used to feed the meters under test with the current and voltage values defined for the load point.

Reference Standard Meter and Control Unit

The installation has an integrated system reference standard of the type SRS 121.3, which uses a digital system of measurement. It measures the load values directly in the circuit of the meters under test.

The output data, as well as the measurement results, are transferred to the personal computer, where stored into the memory.

All measurement values and meter errors are available for display as required on the computer terminal.

Additionally, an error display unit at each meter position is available. For the quick and efficient calibration of Ferraris meters, a push button at each meter position allows test for individual meters to be repeated.

Mechanical Assembly

This comprises the power source cabinet on one hand, and the suspension rack with built-in working surface on the other. The rack, of aluminium construction, can accommodate up to twenty meters, each position accessible by a scanning head which can be laterally moved along the guide rail. The scanning heads are adjustable both in depth and height as required.

Software CAMCAL

The software package CAMCAL comprises the routines for the commands to the power source as well as those for the meter adjustment, measurement and reporting procedures.

Commissioning

The modular design of the system makes it easy for the user to assemble the equipment in his premises and put it into operation. The delivery includes completely cabled and tested component parts as well as an extensive mounting and commissioning guide.



a) Test of emitting contacts
b) Tariff read out system

The following options a) to f) are available



f) Three or six relay tariff circuits for tariff control



c) Hand terminal numerical or alphanumerical

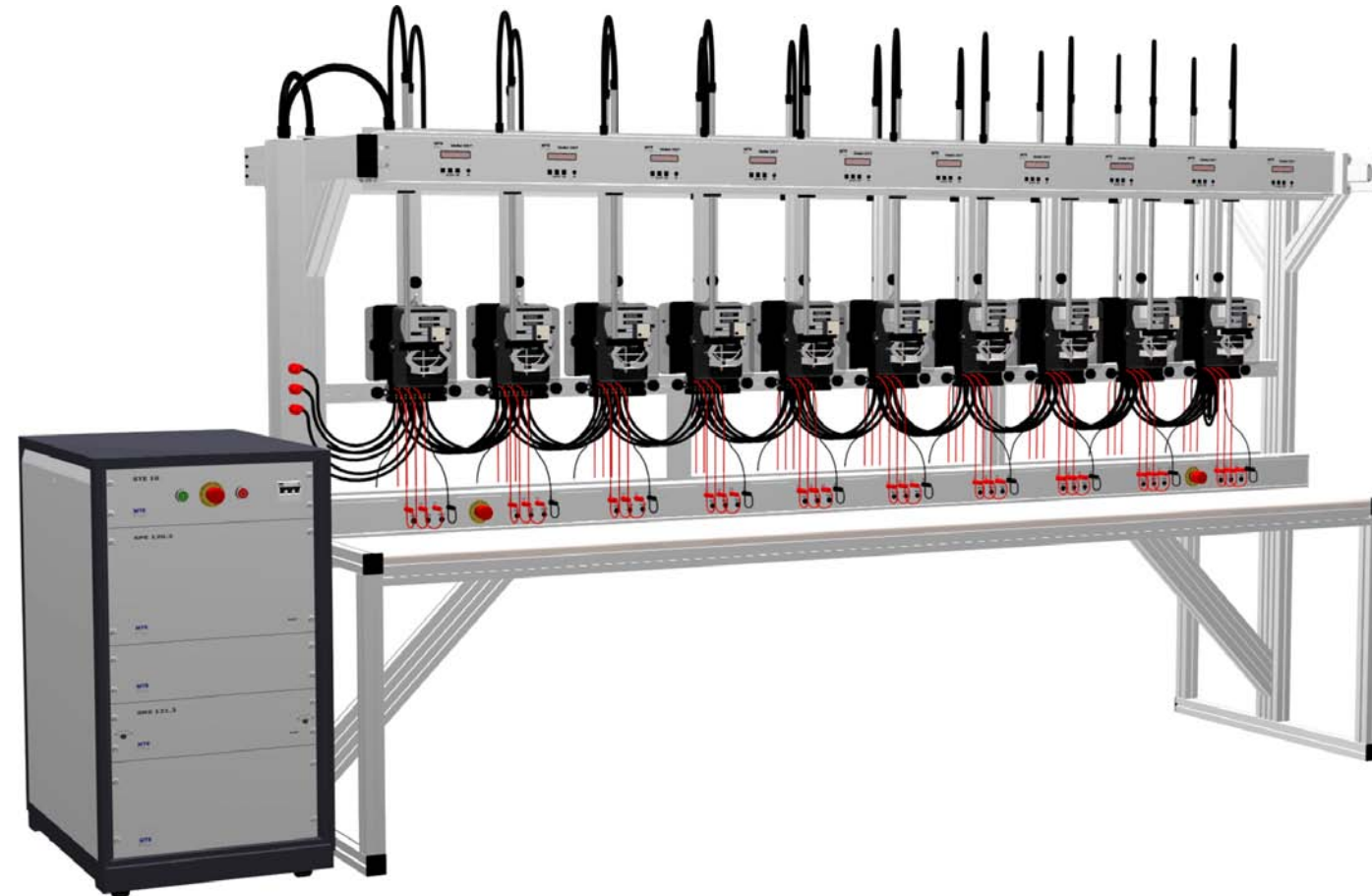

e) Personal computer with printer

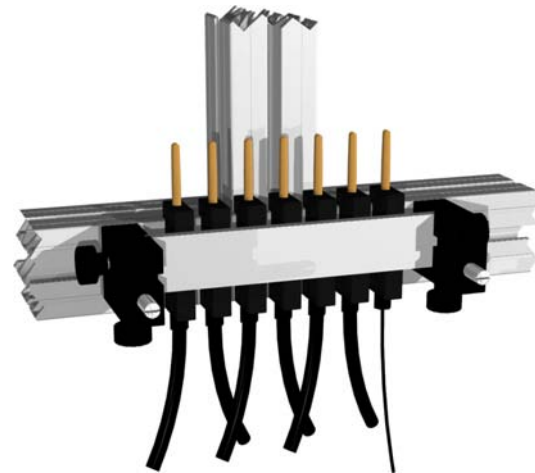

d) Quick connection device current only

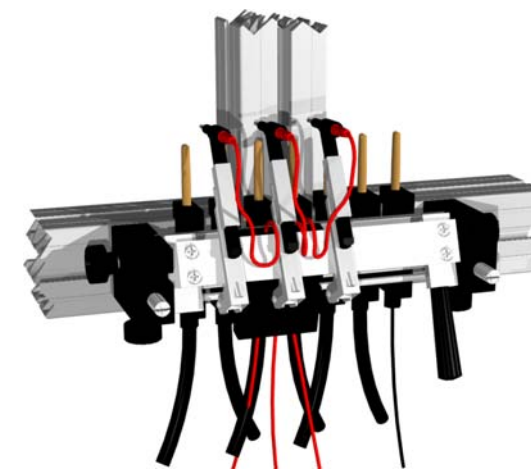

d) Quick connection device current and voltage

Technical description MTE-S 20.20

Power supply voltage

Standard: 3 x 230 / 400 V \pm 15 %
45 ... 65 Hz

(Other voltages are available on request)

Assembly: 19 inch cabinet, 20 height modules

Electronic Power Source

Voltage ranges

Three internal ranges (30 ... 300) V

Output Power 600 VA

Current ranges

Six internal ranges (1 mA ... 120) A

Output Power 600 VA

Phase angle

Range: 0° ... 360°

Resolution: 0.01°

Load regulation: 0.01 %

Distortion factors: \leq 0.5 % (voltage)

(linear load) \leq 0.5 % (current)

Frequency range: 45 Hz ... 65 Hz

Efficiency at full load: $>$ 85 %

Stability: (tm: \geq 5 s) better than 0.05 % / 2 min

(tm: \geq 150 s) better than 0.005 % / h

Voltage circuit: Electronic protection in case of overload and short circuit conditions

Current circuit: Electronic protection in case of overload. Dynamic current limitation. Protection against short circuits between U & I.

SRS 121.3 - Electronic System Reference Standard Meter

Electronic standard meter in three phase configuration for measuring of two, three and four wire meters. It includes a mode selector to measure both active and reactive meters in the ranges of:

Current: (1 mA ... 120) A

Voltage: (30 ... 480) V

Measurement uncertainty: \leq 0.05 % valid for every measurement of the mentioned ranges in relation to apparent power

Control Module

The control module performs the following functions:

- Centralised on-off switch, emergency stop switch
- Supervision of the mains power supply
- Interface with power supply for the scanning heads

Construction

Meter Suspension Rack

The aluminium suspension rack, 3100 mm long, is designed for operation with twenty meter positions. It carries the rails on which the single or three phase meters will be supported and tested, at the same time it includes the terminals for the current and voltage connections.

There are also guide rail supports with both vertical and horizontal adjustment devices for use with the scanning heads. These are SH 2003 type scanning heads with a switchable LED for both impulse and disc mark detection. Each position is equipped with an error indicator unit.

Cable set

The installation is completely delivered with a set of voltage and current cables for ten meters. The current cables may be used with all values up to 60 A.

Error Display Units

Twenty error display units each having 8 digits, 5 mm high and a push button for the individual start of the new measurement.

Hardware and Software

System Computer Unit

The console is delivered optionally with a personal computer.

Software CAMCAL

Operational Features:

Measurements:

- Fully automatic tests in certification procedures
- Semi automatic tests for calibration of Ferraris meters
- Manual operation for all modules on the test station
- Sample tests (Option)

Data base modules:

- Files for meter types and measuring runs
- Creation and treatment of measuring data for each individual meter number
- Files for test report masks
- Generator for test report masks

Data Presentation and Treatment:

- Presentation of test reports on the monitor
- Print out of test reports
- Data transfer into ASCII File
- Good/Bad evaluation of measuring results (Option)

Options

The following options are available:

a. Module Test of Emitting Contacts

Additional entry on the meter error evaluation system for test and measurement of emitting contacts or SO impulses

b. Tariff Device Read-Out System

The tariff read-out system is used for reading automatically the tariff device information from metering equipment according to IEC 1107 this before, during and after the measurement processes

c. Hand Terminal numerical or alphanumerical

Wire less Hand Terminal with or without bar code reader

d. Quick Connection Devices

Twenty quick connection devices for single and three phase meters in two options for current only or for both current and voltage

e. Personal computer, Printer

Personal Computer for control of the meter test console and for display of measuring values and error values. Printer for printout of test reports

f. Relays tariff circuits for tariff control

As an option 3 or 6 tariff relay control circuits are available